

Réf.	Quantité	Titre/Nom, désignation, matière, dimension etc			Article No./Référence	
Dessiné par A - D	Controlé par R.M	Approuvé par - date	Modifié le	Nom fichier	Echelle 1 / 1	
 SEED GAMMISTE ZA le V Pontaubault BP 132 50301 AVRANCHES Cedex Tél: 02.33.89.02.83 / Fax: 02.33.89.59.33 E-mail: desfoux@seedgammiste.com				FICHE TECHNIQUE P810 SUSPENDU		
				Version	Format	

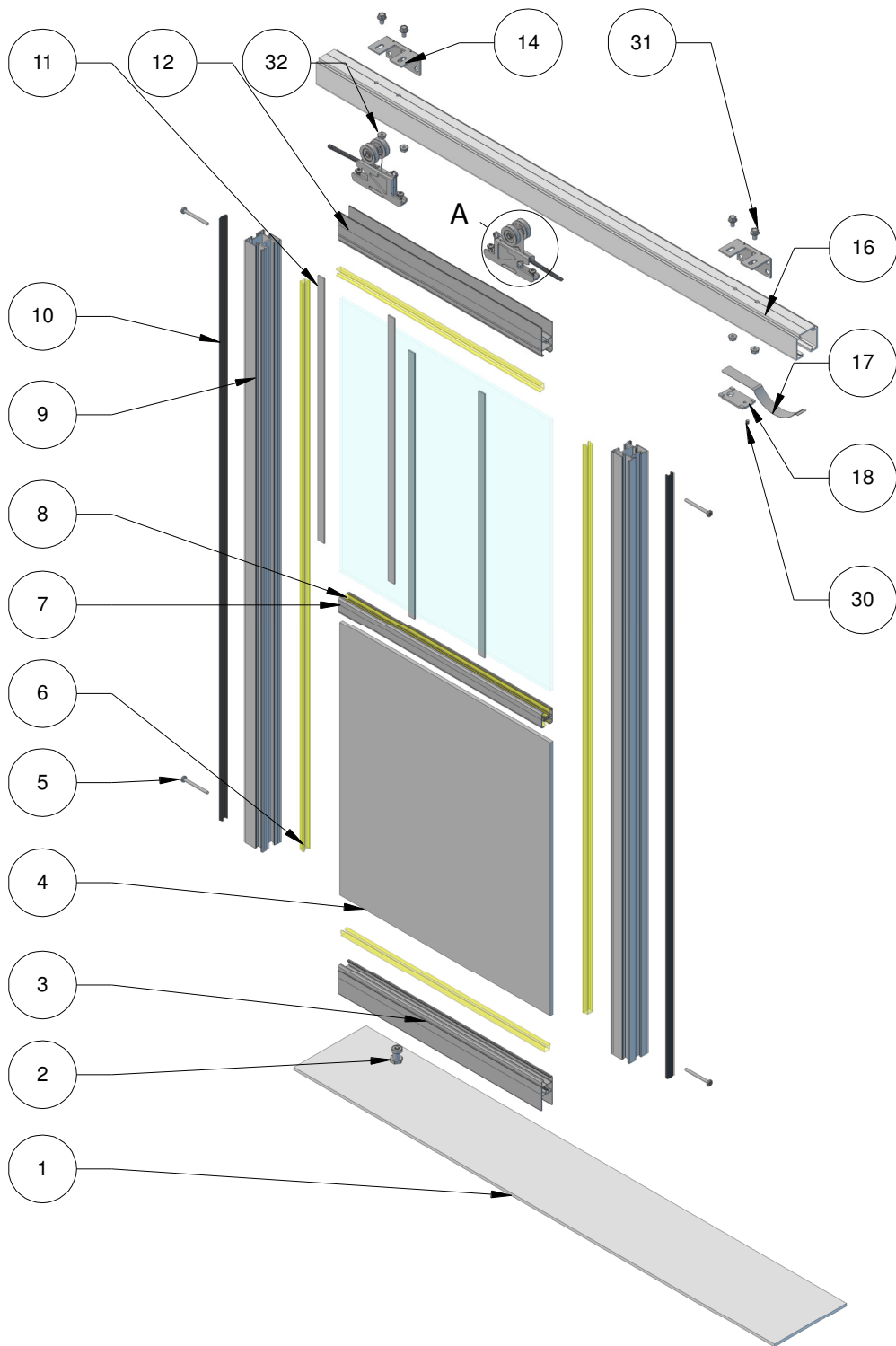
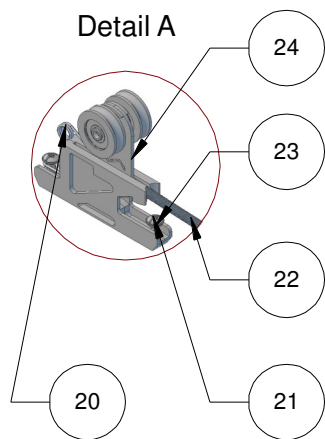

N°	QTE	NOM DE LA PIECE
1	1	sol
2	1	Guide bas
3	1	Traverse basse
4	2	Remplissage
5	4	Vis 4.5X50
6	2	Profil de vitrage 6-8mm (poignée)
7	1	Traverse intermédiaire 27mm
8	4	Profil de vitrage 6-8mm (traverse)
9	2	Poignée P810
10	2	Joint de finition
11	4	Plat à coller 25 MM
12	1	Traverse haute
14	2	Equerre de suspension rail
16	1	Rail haut simple
17	1	Lame de frein non enrobée
18	1	Platine frein lamelle baseo
20	2	Ressort de torsion insert
21	4	Vis 5X16
22	2	Vis 6X80
23	2	Rondelle
24	2	Chariot
30	1	Vis Mx STHC 5X5 bout cuvette
31	4	Vis Mx TH 6x10 embase crantée :
32	4	Ecrou TH M6 embase crantée

Réf.	Quantité	Titre/Nom, désignation, matière, dimension etc			Article No./Référence	
Dessiné par A - D		Contrôlé par R.M	Approuvé par - date	Modifié le	Nom fichier	Echelle 1 / 1
 SEED GAMMISTE ZA le V Pontaubault BP 132 50301 AVRANCHES Cedex Tél: 02.33.89.02.83 / Fax: 02.33.89.59.33 E-mail: desfoux@seedgammiste.com				FICHE TECHNIQUE P810 SUSPENDU		
				Version	Format	

Détermination des cotes de fabrication

L = Cote de passage

I = Largeur porte finie

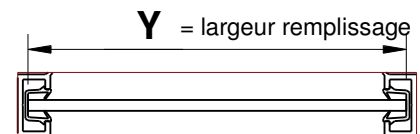
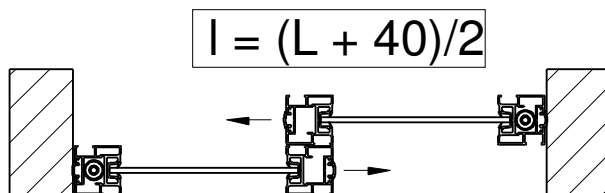
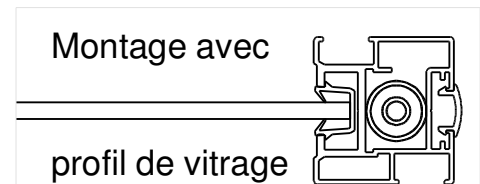
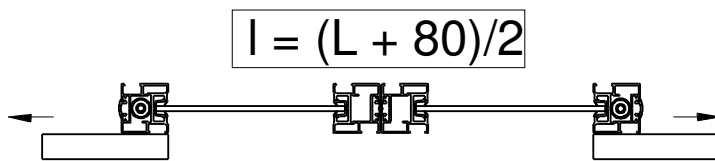
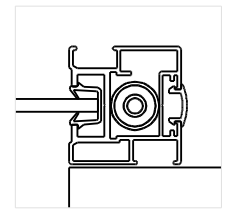
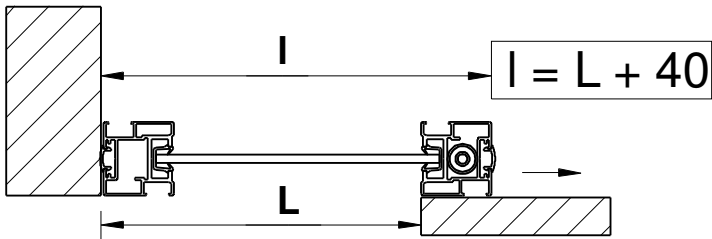

$X = H - 152 \text{ mm}$

$Y = I - 62 \text{ mm}$

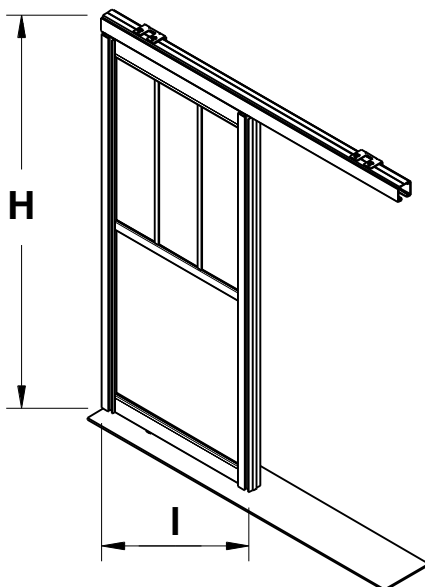

Traverses haute et basse = $I - 77 \text{ mm}$

Rail haut = à préciser

Poignées = $H - 60 \text{ mm}$

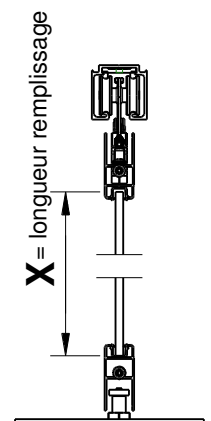

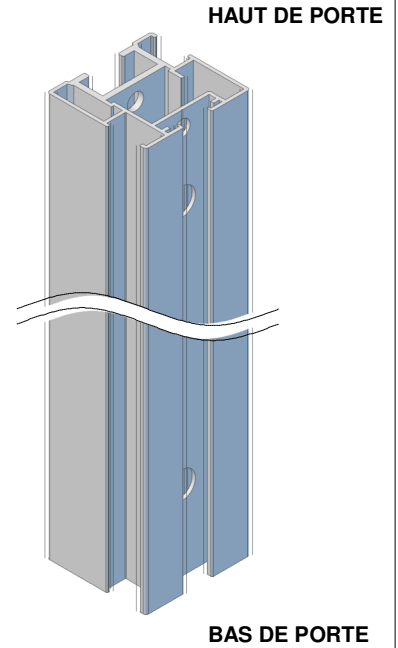
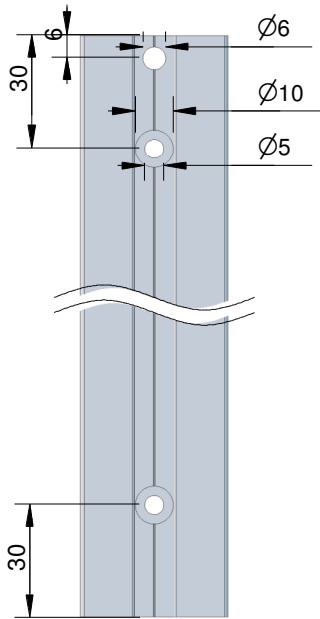

Réf.	Quantité	Titre/Nom, désignation, matière, dimension etc			Article No./Référence		
Dessiné par A - D	Controlé par R.M	Approuvé par - date	Modifié le	Nom fichier	Echelle 1 / 1		
 SEED GAMMISTE ZA le V Pontaubault BP 132 50301 AVRANCHES Cedex Tél: 02.33.89.02.83 / Fax: 02.33.89.59.33 E-mail: desfoux@seedgammiste.com				FICHE TECHNIQUE P810 SUSPENDU		Version	Format

COTE JOINT DE FINITION

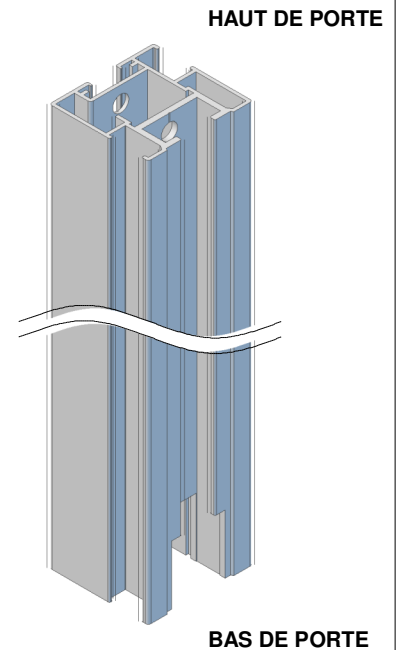
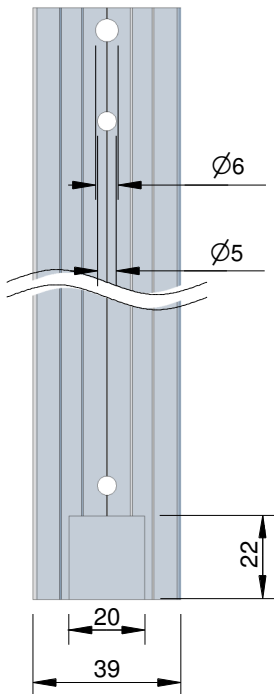

COTE REEMPLISSAGE



Réf.	Quantité	Titre/Nom, désignation, matière, dimension etc			Article No./Référence	
Dessiné par A - D	Contrôlé par R.M	Approuvé par - date	Modifié le	Nom fichier	Echelle 1 / 1	
 SEED GAMMISTE ZA le V Pontaubault BP 132 50301 AVRANCHES Cedex Tél: 02.33.89.02.83 / Fax: 02.33.89.59.33 E-mail: desfoux@seedgammiste.com				FICHE TECHNIQUE P810 SUSPENDU		
				Version	Format	

USINAGE TRAVERSE HAUTE

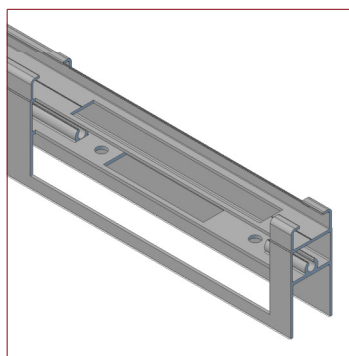
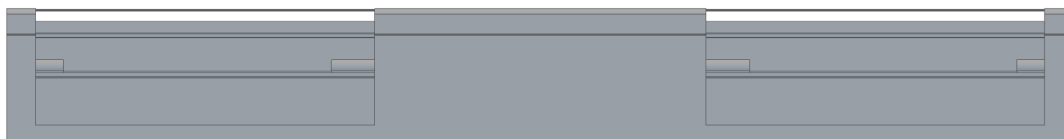

COTE CHARIOT

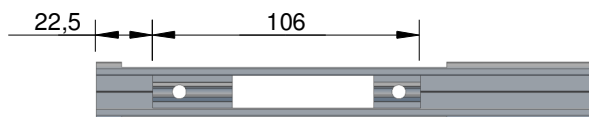

COTE REPLISSAGE

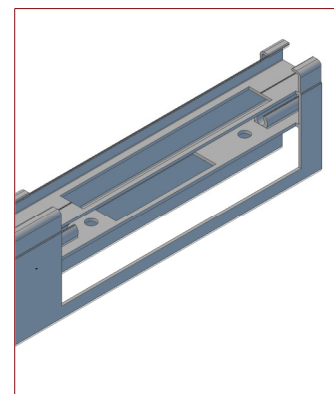
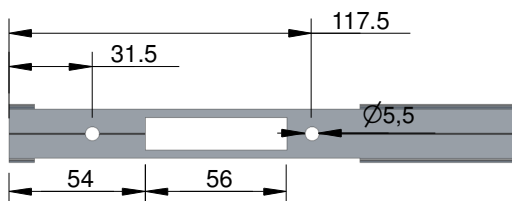

Réf.	Quantité	Titre/Nom, désignation, matière, dimension etc			Article No./Référence	
Dessiné par A - D	Controlé par R.M	Approuvé par - date	Modifié le	Nom fichier	Echelle 1 / 1	
 SEED GAMMISTE ZA le V Pontaubault BP 132 50301 AVRANCHES Cedex Tél: 02.33.89.02.83 / Fax: 02.33.89.59.33 E-mail: desfoux@seedgammiste.com				FICHE TECHNIQUE P810 SUSPENDU		
				Version	Format	