

P700 - P710

Présentation

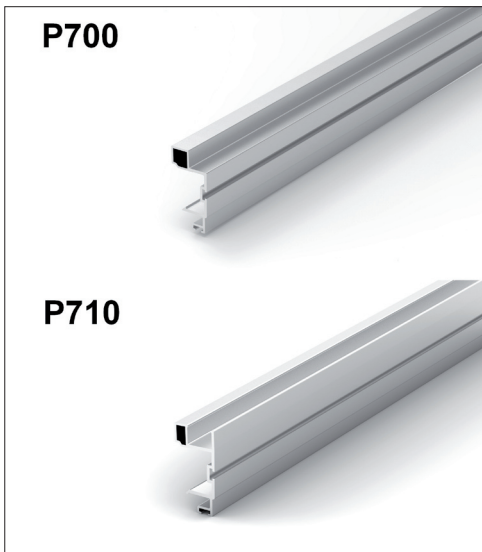

Composants principaux

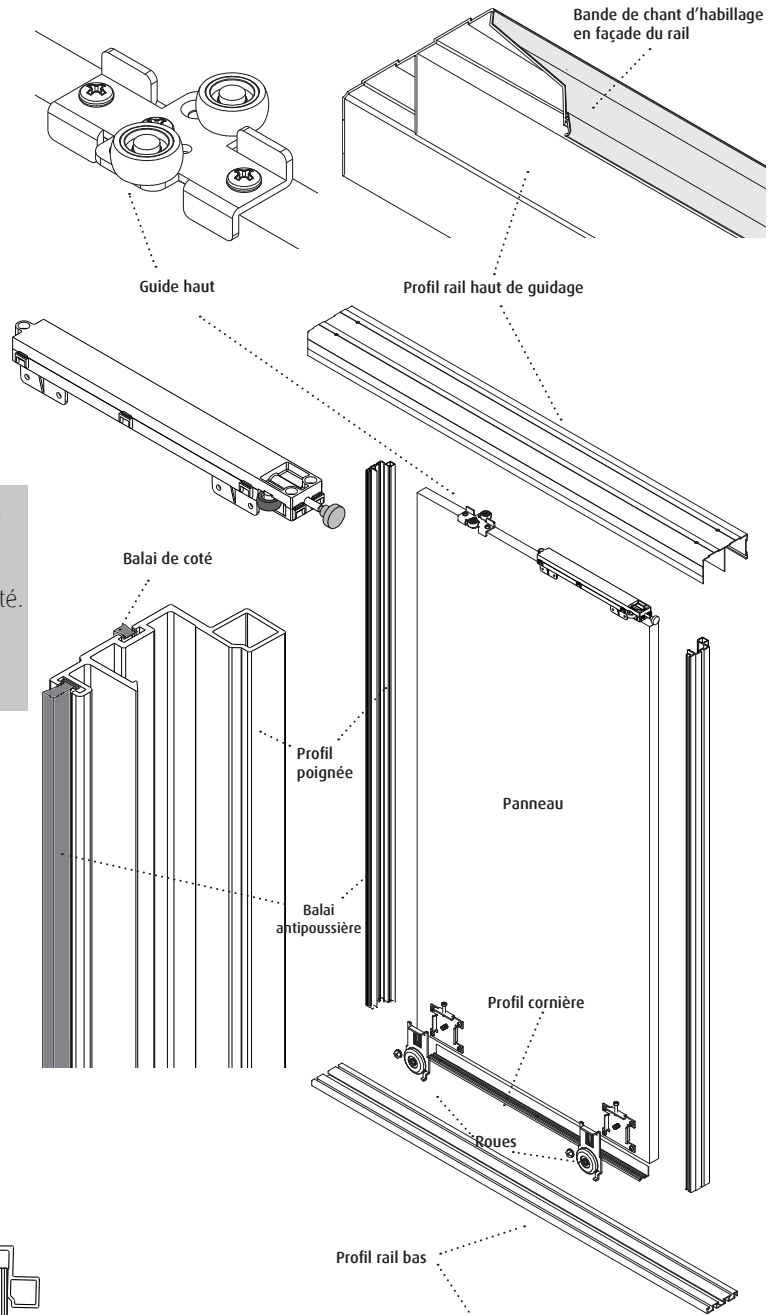

Hauteur maxi: 2600mm Largeur mini/maxi: 500-1100mm
 Remplissages: - Mèlaminé: 19mm
 - Mèlaminé + (miroir ou verre): 15+4mm
 Finitions profils : aluminium anodisés, laqués, polis et chromaté.
 Platine roue: roulement à billes de précision étanche à la poussière avec un bandage de ø42.
 Système antidéraillement.

Coupe verticale d'une installation

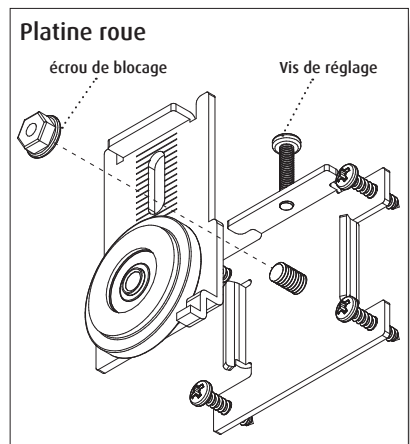
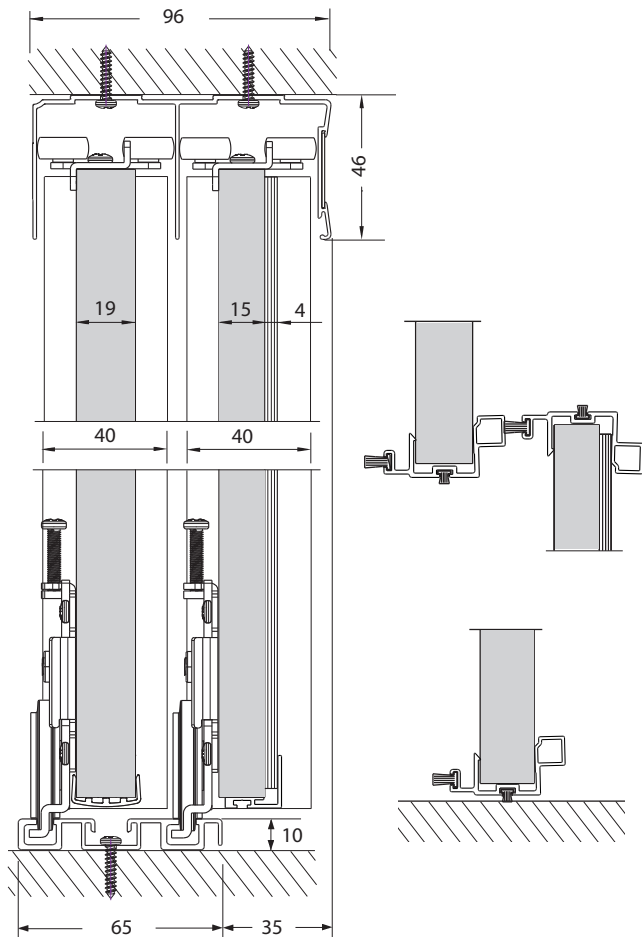

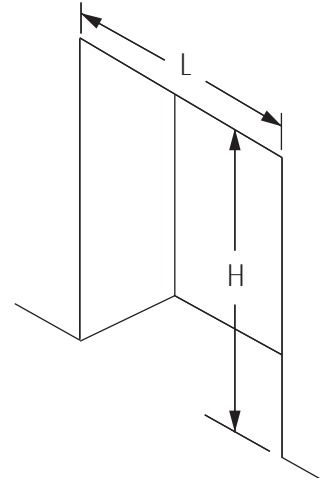
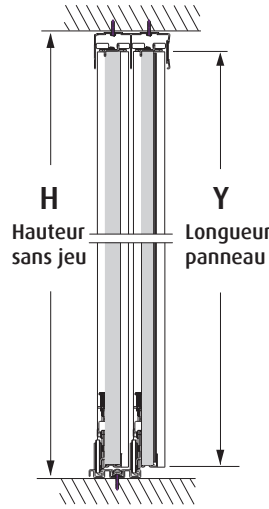

Hauteur H =	Largeur L =	RESULTAT	Quantité
A) Débit panneau (Ep = 15 ou 19mm) <ul style="list-style-type: none"> • Y (Longueur du panneau sans frein amortisseur) = H-39mm..... • Y (Longueur du panneau avec frein amortisseur) = H-47mm..... • X (Largeur du panneau) 			
1			
2			
3			
4			
5			
B) Débit Aluminium <ul style="list-style-type: none"> • Rail haut = L (Longueur façade)..... • Rail bas = L (Longueur façade)..... • Poignée = Y (Panneau)..... • Cornière = X-28 mm..... 			
C) Débit miroir <ul style="list-style-type: none"> • Longueur = Y-2 mm..... • Largeur = X-2 mm..... 			

Façades japonaises

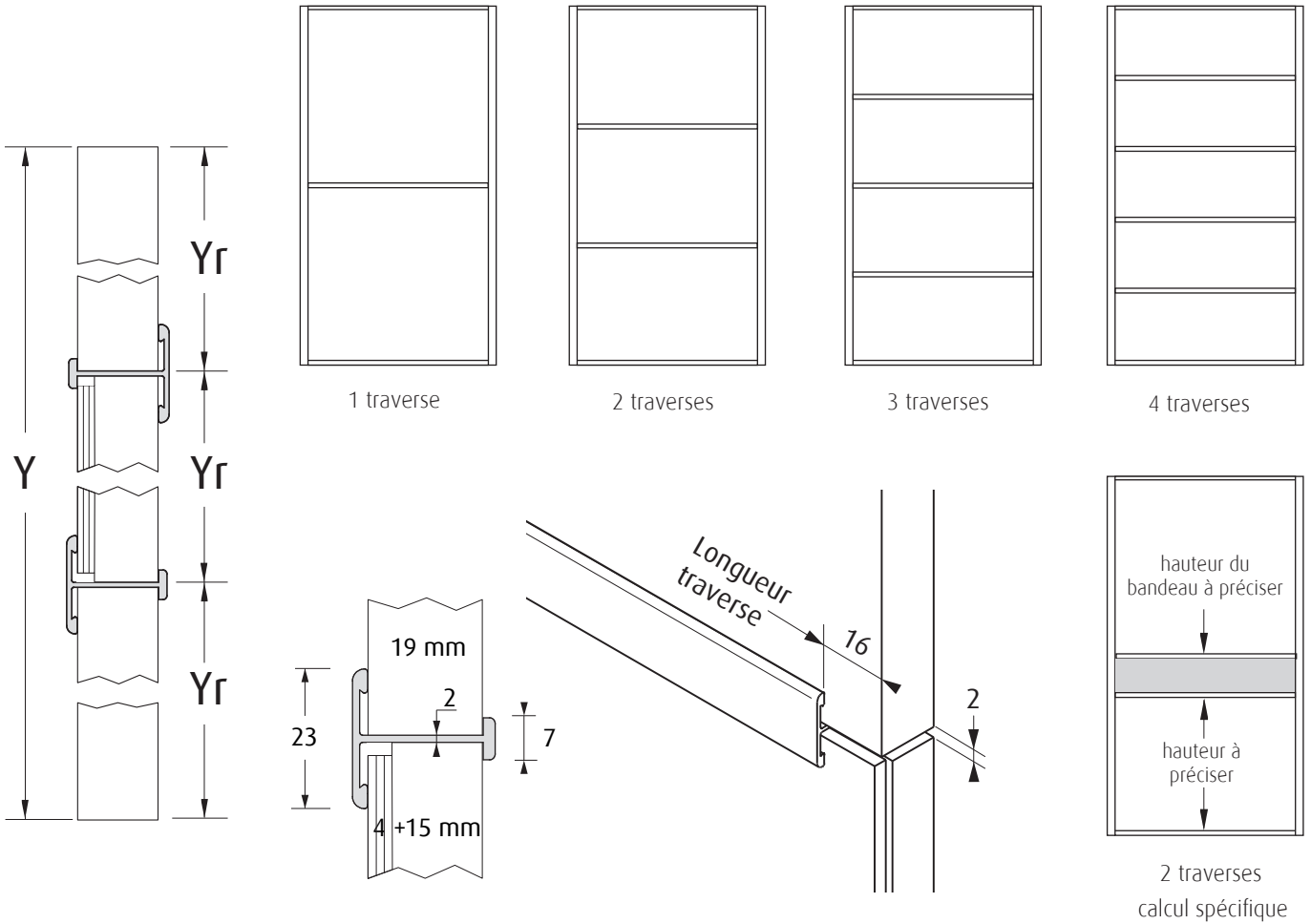

Y (Longueur panneau)=

X (Largeur panneau)=

⚠ Calcul de Y et X page précédente

A) Débit remplissage (Ep = 15 ou 19mm)

• Yr (Longueur du remplissage) = $\frac{Y - (2 \text{ mm} \times \text{nombre de traverses})}{\text{Nombre de remplissages}}$

• Xr (Largeur du remplissage) = X (Largeur du panneau).....

B) Débit Aluminium

• Traverse intermédiaire 7 ou 23 mm = Xr- 32 mm.....

C) Débit miroir

• Longueur = Yr-2 mm.....

• Largeur = Xr-2 mm.....

RESULTAT	Quantité

P700 - P710

Adaptations spéciales

Façade en pan coupé avec guidage sous tablette

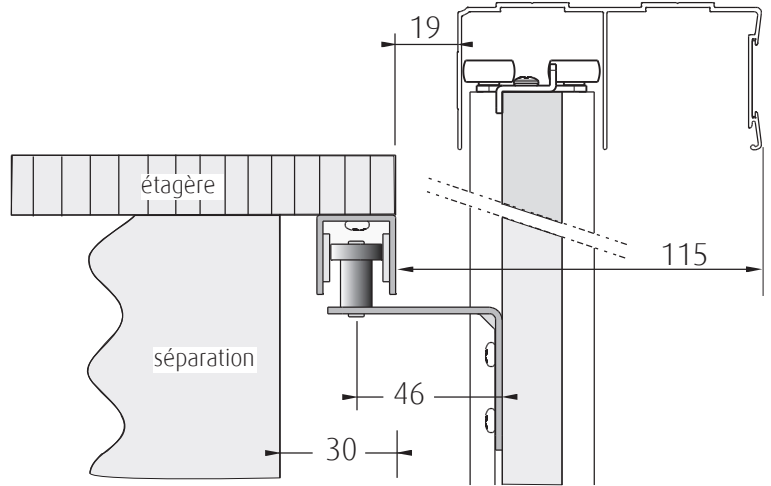
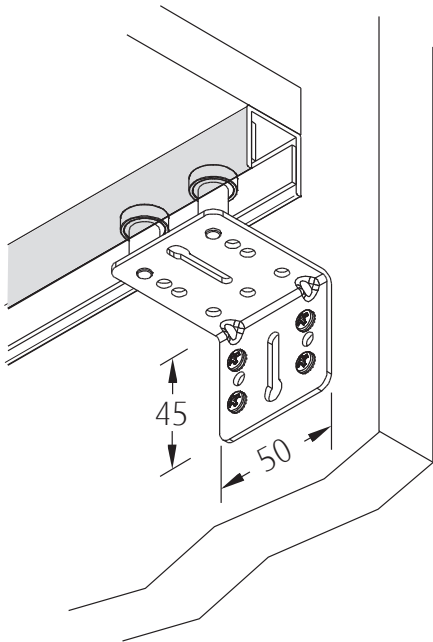

Solution 1 : Porte sans guidage sous tablette

1/3 de largeur et minimum 200 mm

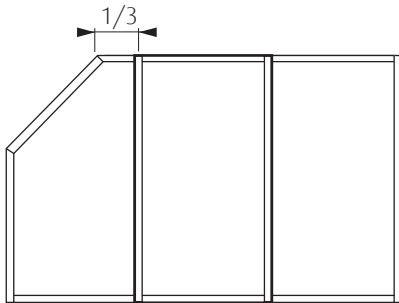

Solution 2 : Porte avec guidage sous tablette

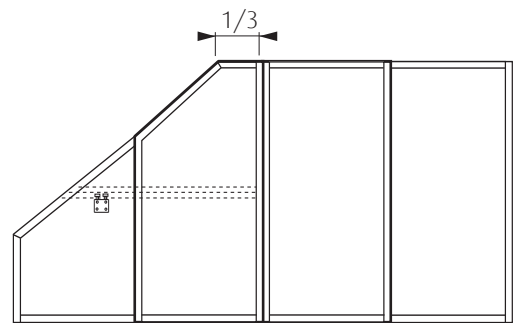

Façade avec serrure à bascule encastrée

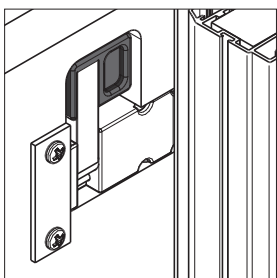

Ouvert

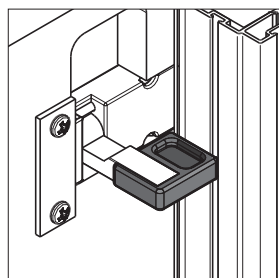

Fermé

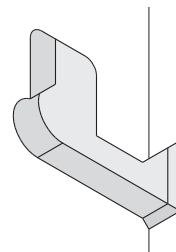

Usinage dans le panneau
(voir page 5)

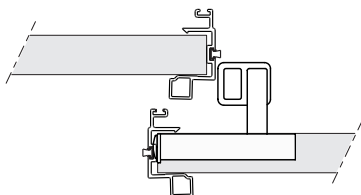
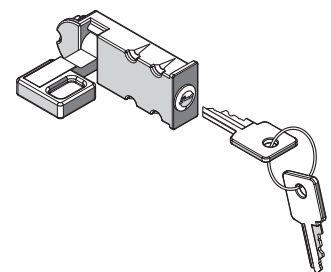

Façade à 2 portes

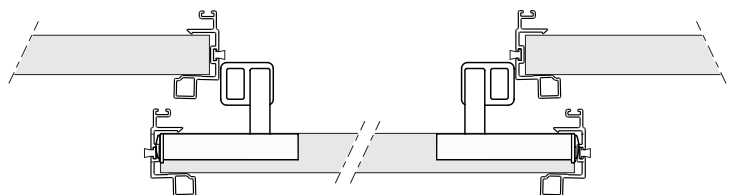

Façade à 3 portes

P700 - P710

Usinage et perçages

Fixation des platines panneau

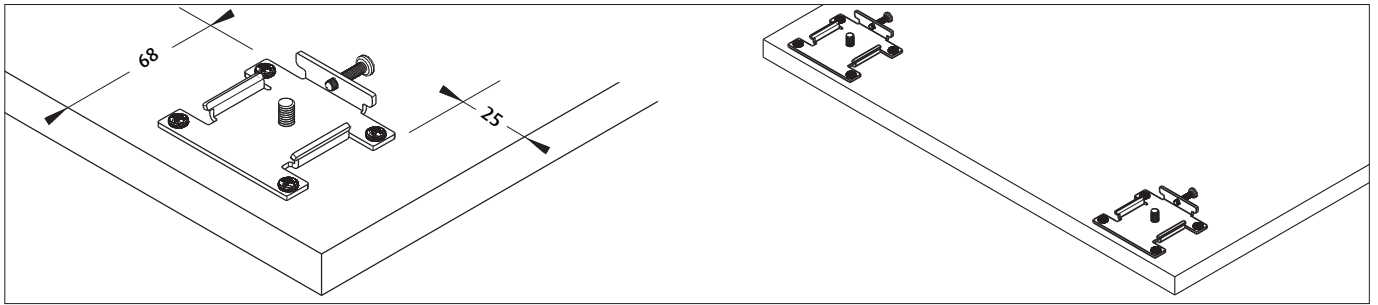

Usinage pour serrure

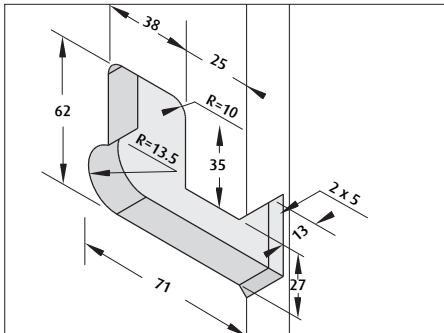

Perçage pour serrure

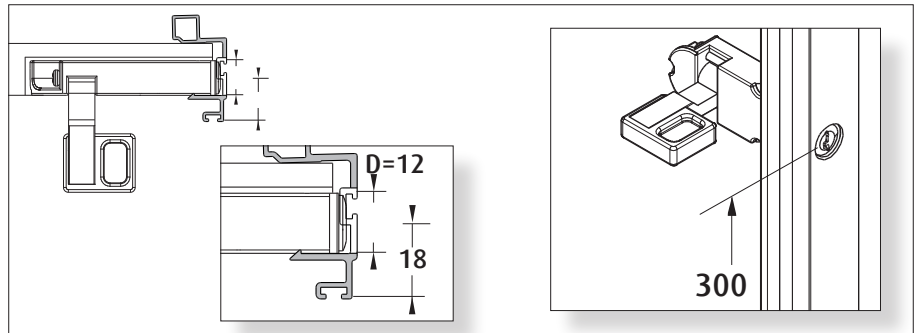

Perçage des rails et cornière

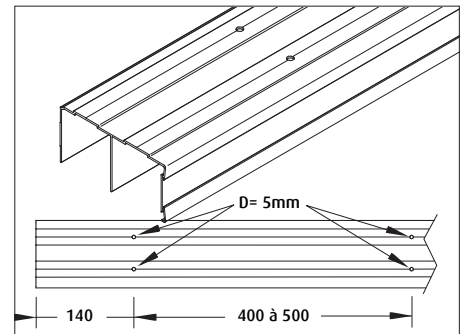
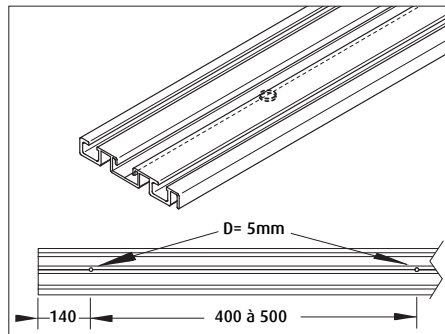
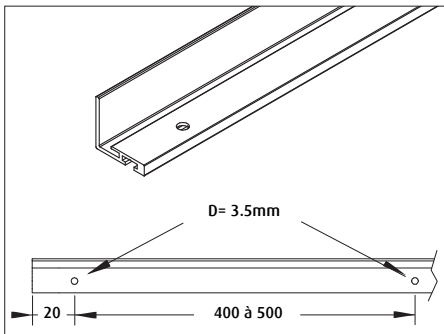

Détail de positionnement des profils

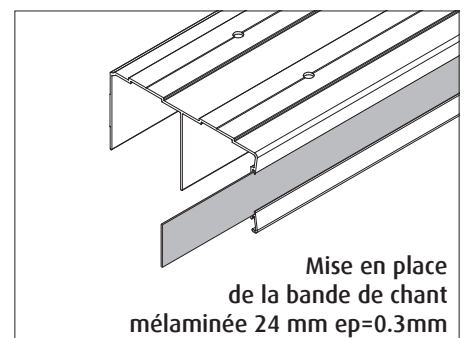
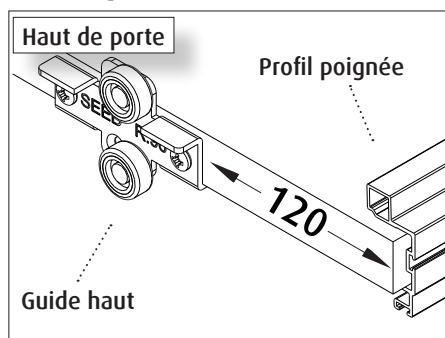
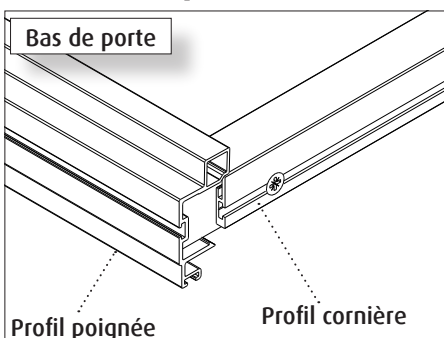

Détail de positionnement du frein amortisseur

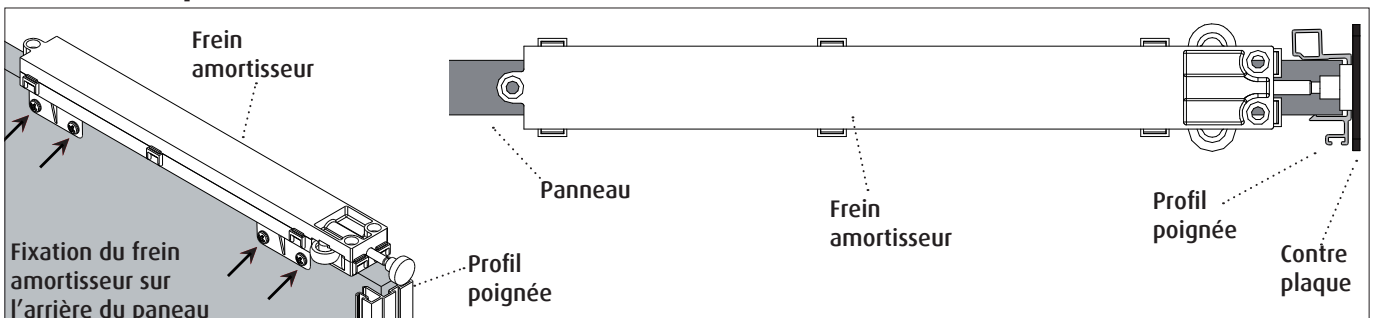

P700 - P710

Préparation des
panneaux

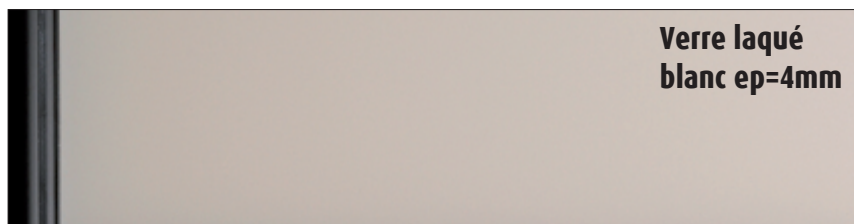

Collage d'un miroir ou verre laqué

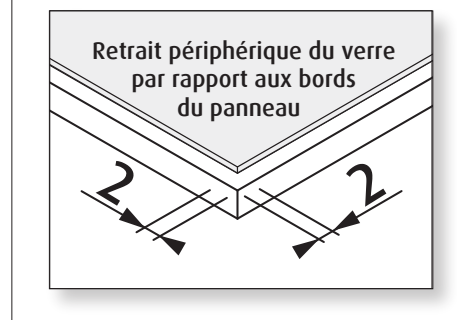
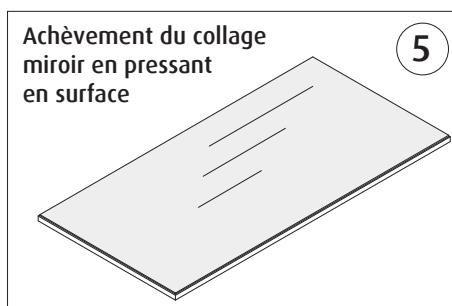
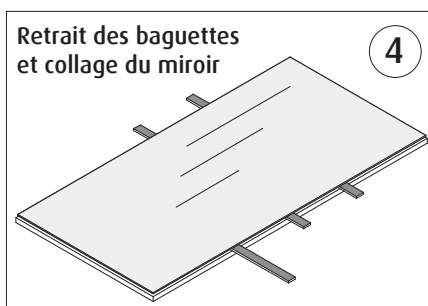
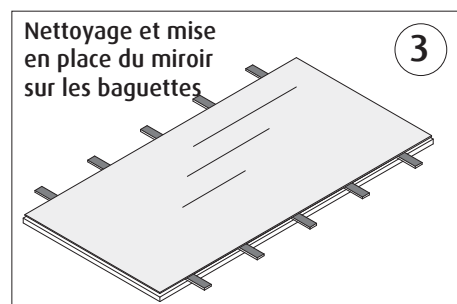
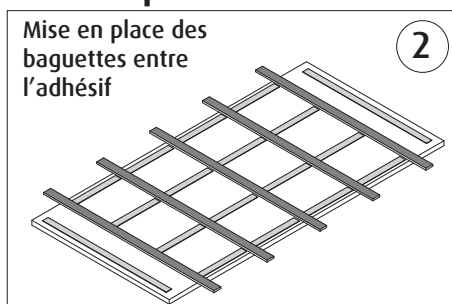
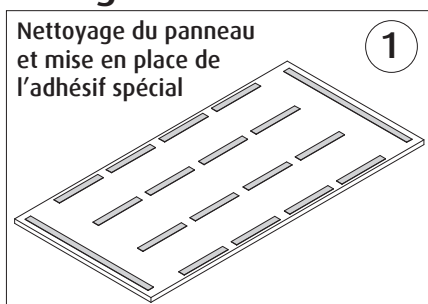

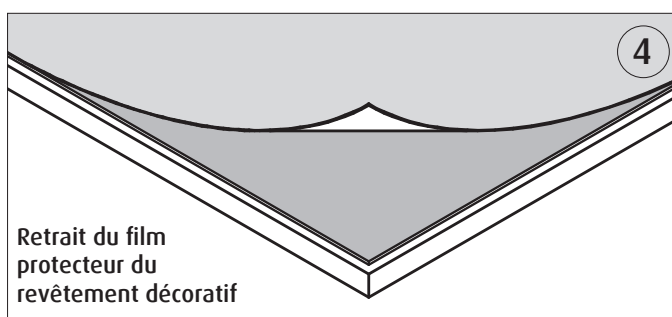
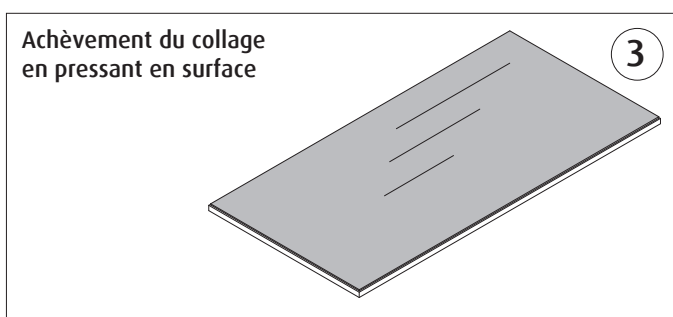
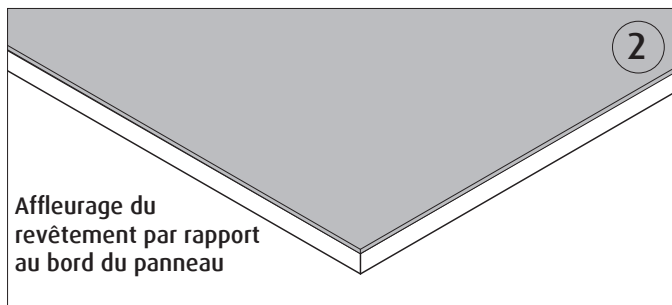
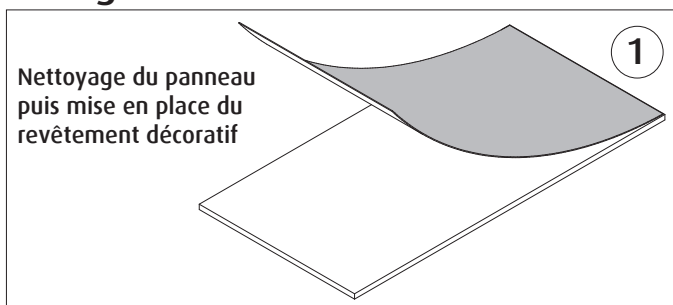

Collage d'un revêtement décoratif

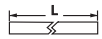
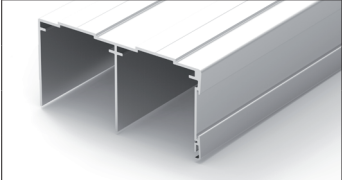
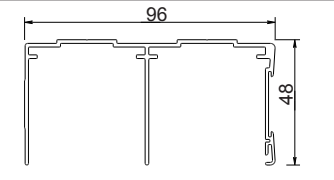
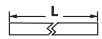
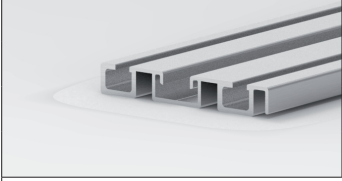
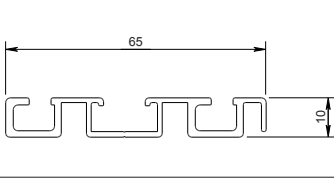
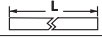
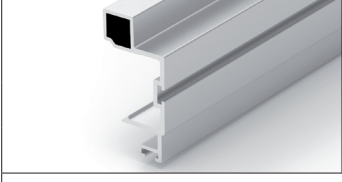
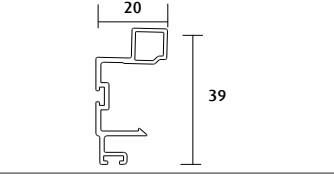
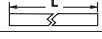
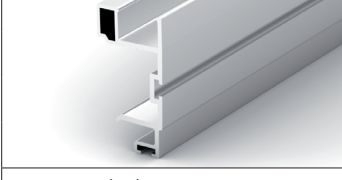
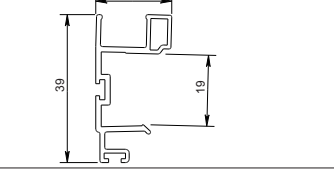
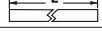

P700 - P710

Profils et accessoires

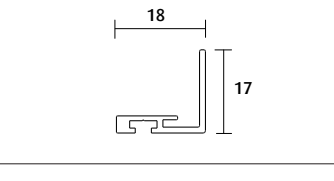
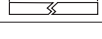
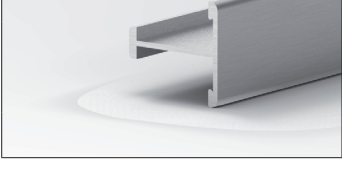
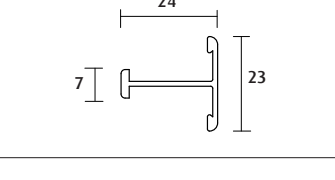
Rail haut			Code	Finitions
		5.14 m	RH96	Anodisés: satiné argent Laqués: blanc, noir Brossés: inox
Rail bas			Code	Finitions
		5.14 m	RB65	Anodisés: satiné argent Laqués: blanc, noir Brossés: inox
Poignée P700			Code	Finitions
		5.14 m	P700	Anodisés: satiné argent Laqués: blanc, noir Brossés: inox
Poignée P710			Code	Finitions
		5.14 m	P710	Anodisés: satiné argent Laqués: blanc, noir Brossés: inox
Cornière balais			Code	Finitions
		5.14 m	CCLA	Anodisés: satiné argent Laqués: blanc, noir Brossés: inox
Traverse intermédiaire			Code	Finitions
		5.14 m	TI19	Anodisés: satiné argent Laqués: blanc, noir Brossés: inox